

## Gas spring G 10-28 V4

<b>Extension force F1</b>	100 - 1200 Newton
<b>Progression</b>	20 %
<b>Piston rod</b>	Ø 10 mm, W. 1.4404 / AISI 316 L
<b>Cylinder</b>	Ø 28 mm, W. 1.4571 / AISI 316 Ti
<b>Endfittings</b>	W. 1.4404 / AISI 316 L

GZ 10

GZ 10

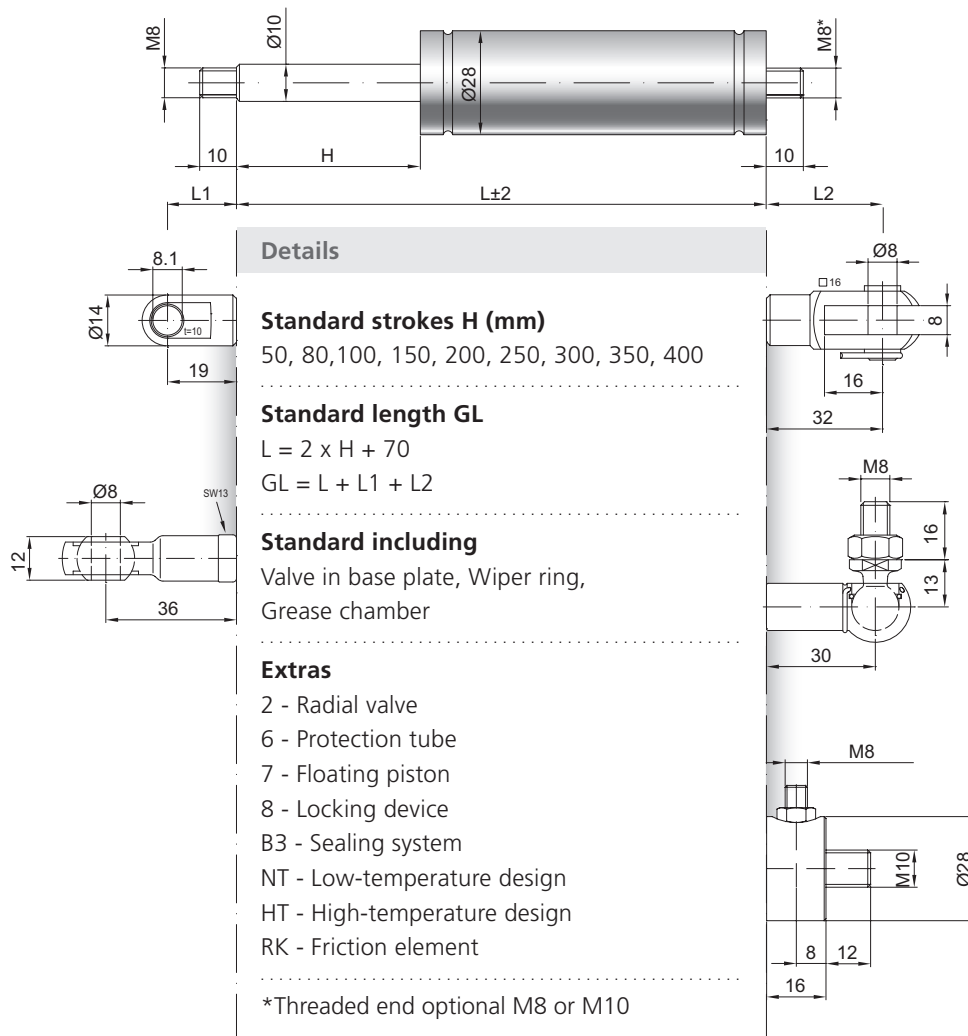

AU 19

GG 32

AG 36

WG 30

QV GZ

More **endfittings** can be found here [▶](#)

**Matching brackets** can be found here [▶](#)