

Gas spring G 20-40 V2

Extension force F1 300 - 5000 Newton
Progression 40 %
Piston rod Ø 20 mm, W. 1.4305 / AISI 303
Cylinder Ø 40 mm, W. 1.4301 / AISI 304
Threads W. 1.4305 / AISI 303

GZ 15

GZ 15

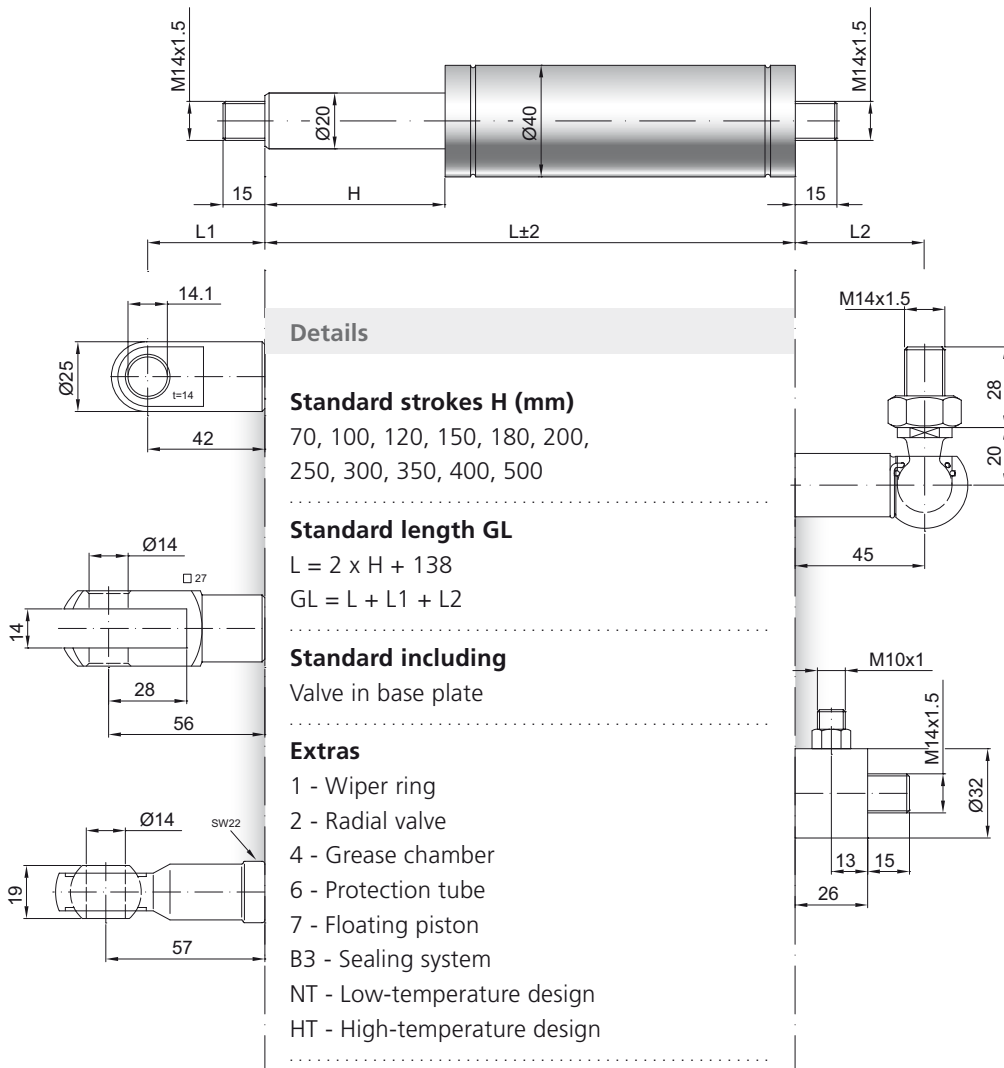

AU 42

WG 45

GA 56

QVGZ

AG 57